



## Sales and Support Phone Contact Numbers

### ITALY

Eliwell Controls s.r.l. - Pieve d' Alpago (Belluno)

Telephone +39 0437 986 111

Facsimile +39 0437 989 066

Sales +39 0437 986 100

E-mail [saleseliwell@invensys.com](mailto:saleseliwell@invensys.com)

Technical helpline +39 0437 986 300

E-mail [techsuppeliwell@invensys.com](mailto:techsuppeliwell@invensys.com)

### SPAIN - Eliwell Iberica S.A. - Valencia

Telephone +34 (0) 96 313 40 49

Facsimile +34 (0) 96 350 07 87

### FRANCE - Eliwell France - Paris

Telephone +33 (0) 1 41 47 71 71

Facsimile +33 (0) 1 47 99 95 95

### RUSSIA - Moscow Office - Moscow

Telephone +7 095 111 7975

Facsimile +7 095 111 7829

### GERMANY - Eberle GmbH - Nürnberg

Telephone +49 (0) 911 56 93 586

Facsimile +49 (0) 911 56 93 560

E-mail [techsuppeliwell@invensys.com](mailto:techsuppeliwell@invensys.com)

### OTHER COUNTRIES

Telephone +39 0437 986 111

Facsimile +39 0437 989 066

Sales +39 0437 986 200

E-mail [saleseliwell@invensys.com](mailto:saleseliwell@invensys.com)

Technical helpline +39 0437 986 300

E-mail [techsuppeliwell@invensys.com](mailto:techsuppeliwell@invensys.com)

[www.invensyscontrolseurope.com/ranco/](http://www.invensyscontrolseurope.com/ranco/)

# 4-Way Reversing Valves



People



Products



Performance

- Wide Application Range
- High Reliability
- Minimum Pressure Drop
- Low Leakage Risk
- UL Approved



# Application and Principle of Operation



The 4-way Reversing Valve is the key component to provide Heating and Cooling from the system to the air conditioned space by reversing the flow direction of refrigerant. It is used at room air conditioners, packaged and central air conditioners. The reversing Valves are designed for Heat Pump Systems with capacity from 3kW to 580kW. They are suitable for most refrigerants as R407C - R410A - R134A.

## Coil energized

The 4-way valves are used in reversible applications such as heat pumps or reversible air conditioning units and chillers.

The 4-way valve allows an inversion of the refrigeration cycle, changing from cooling mode in Summer to heating mode in Winter.

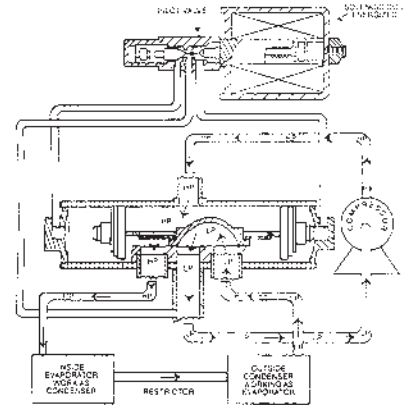

Heating Cycle

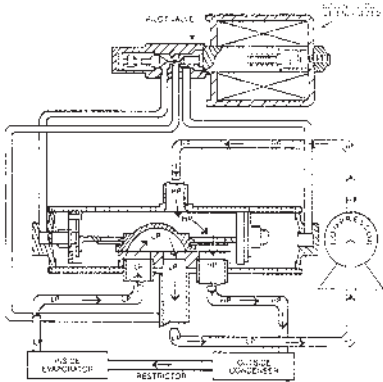

Cooling Cycle

The cycle inversion is initiated by a small solenoid pilot valve, which triggers the movement of a slide, thus inverting the flow direction of the refrigerant.

The valve is connected to the suction and discharge pipes.

The pilot valve ensures a very reliable changeover from cooling to heating mode; the changeover happens instantaneously with a minimum pressure differential.

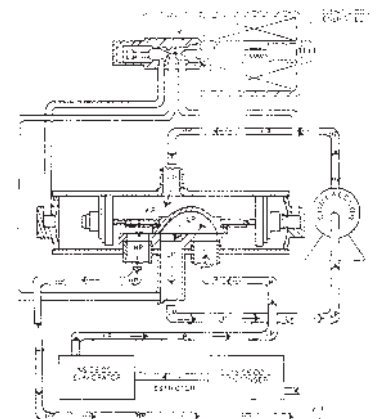

Cooling Cycle

The valve design also guarantees a minimum pressure drop and very low risk of leakage.

The models offer a wide range of connection sizes, configurations and capacity for specific applications. The standard models are available in small quantities per box providing increased flexibility.

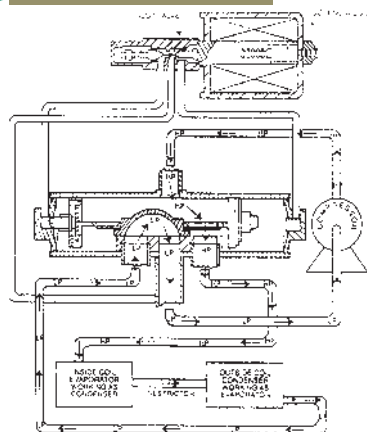

Heating Cycle

## Coil de-energized

# Installation and Cautions

## Notice

Heat pumps and heat/cool units: many original equipment manufacturers connect the system tubing to the Ranco reversing valve based on which mode (heat or cool) the system will operate, should the solenoid coil fail.

For example, solenoid coil energized for cooling (Figure 1); solenoid coil failure mode to heat cycle.

Solenoid coil energized for heating (Figure 2); solenoid coil failure mode to cooling cycle.

Prior to replacing the valve, confirm which mode (heat or cool) the solenoid coil controls when energized.

Viewed facing three tubes and solenoid on right.

Solenoid coil fails, cycle goes to heating. Solenoid coil energized for cooling (de-energized for heat); solenoid fails, valve goes to heat cycle.----



Figure 1

1. Connects to Compressor Discharge
2. Solenoid Coil Energized for Cooling
3. Connects to Outside Condenser
4. Connects to Suction Line
5. Connects to Inside Evaporator (coil)
6. Solenoid Coil Energized for Heat

Viewed facing three tubes and solenoid on right.

Solenoid coil fails, cycle goes to cooling. Solenoid coil energized for heat (de-energized for cooling); solenoid fails, valve goes to cooling cycle.



Figure 2

## REPLACING VALVE ASSEMBLY

**SYSTEM REPAIR** - Follow the original equipment manufacturer's recommendations for replacement of refrigerant components.

**SYSTEM EVACUATION** - Follow original equipment manufacturer's recommendations and/or RSES SAM Section 83 (630-46).

**COMPRESSOR MOTOR BURNOUT** - Follow original equipment manufacturer's recommendations and/or RSES SAM Section 91.

### CAUTION

To prevent possible electrical shock or equipment damage, disconnect electrical power to unit before and during installation.

DO NOT restore electrical power to unit until the device is properly installed.

## GENERAL INSTALLATION PROCEDURES - REMOVAL

- Use only an oxy-acetylene torch to unsolder connections. Other type torches may not have the heat capacity to do the job with minimum time and temperature.
- Protect the valve from excessive heat. Temperatures above 110°C are apt to damage internal parts. Wrapping a wet rag around the valve body while using the torch will help to dissipate heat.
- Inadequate heat is also a problem.

Not only will the soldered joints be difficult to separate, but also the build up of heat over the longer period of time required will transfer to the valve body and possibly damage its internal parts.

- The joint should separate in seconds, not minutes. Use enough heat to accomplish this, while relying on the wet rag to protect the valve body.

Also remember that the remelt temperature of any solder alloy is much higher than the initial soldering temperature.

- After removing the valve, inspect the lines to make sure they are round and do not have any large solder blobs, which will interfere with the mechanical fit of the new joints.

## VALVE INSTALLATION

- Avoid any rough handling of the new valve during installation. This especially includes the use of vise-type pliers to manipulate the valve body while

### CAUTION

Protect tubes from entry of all foreign matter such as moisture, metal filings, dust or dirt. It takes only a tiny bit of scale,

flux, lint or the like to clog a pilot valve

- Use wet rags around the valve body and adjoining tubing to prevent overheating. Direct the flame of the torch away from the valve body. Excess heat over 110°C may distort internal parts.
- Use low temperature brazing rod as local code will permit, and use an inert gas to prevent oxide scale on the inside of the tubing.
- Preferably use a phosphorus-bearing silver solder which requires no external flux. The entrance of even a tiny bit of flux may be enough to damage a new valve
- If you must use silver solder with externally applied flux, be sure the sections to be joined are bright and clean and that you use the flux sparingly. This will do the job, but because this kind exceptional skill and care in its use, most valve manufacturers are reluctant to recommend it.

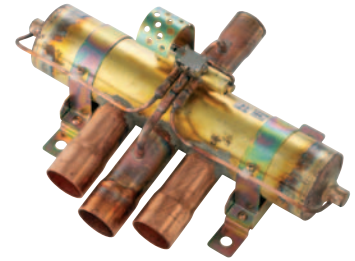

## V-Series



Part Number	R407C kW min/max (US ton min/max)	R410A kW min/max (US ton min/max)	R134A kW min/max (US ton min/max)	C.T.S.				Style	Mass (g) (W/O coil)	Qty/ box	Coil
				S.E.C.		Discharge					
				mm	Inch	mm	Inch				
V0-406050100	1.34 / 3.02 (0.38 / 0.86)	1.55 / 3.83 (0.44 / 1.09)	1.16 / 2.36 (0.33 / 0.67)	9.64	3/8	8.12	5/16	B	210	36	LDL/LDK
V1-408050100	1.41 / 4.57 (0.40 / 1.30)	1.76 / 5.98 (0.50 / 1.70)	1.41 / 3.87 (0.40 / 1.10)	12.84	1/2	8.01	5/16	A	285	36	LDL/LDK
V1-408060100	1.41 / 4.57 (0.40 / 1.30)	1.76 / 5.98 (0.50 / 1.70)	1.41 / 3.87 (0.40 / 1.10)	12.84	1/2	9.67	3/8	A	285	36	LDL/LDK
V1-406060100	1.41 / 4.57 (0.40 / 1.30)	1.76 / 5.98 (0.50 / 1.70)	1.41 / 3.87 (0.40 / 1.10)	9.64	3/8	9.67	3/8	A	285	36	LDL/LDK
V1-406050100	1.41 / 4.57 (0.40 / 1.30)	1.76 / 5.98 (0.50 / 1.70)	1.41 / 3.87 (0.40 / 1.10)	9.64	3/8	8.01	5/16	A	285	36	LDL/LDK
V1-406050200	1.41 / 4.57 (0.4 / 1.3)	1.76 / 5.98 (0.50 / 1.70)	1.41 / 3.87 (0.4 / 1.1)	9.64	3/8	8.12	5/16	B	310	36	LDL/LDK
V1-406060200	1.41 / 4.57 (0.4 / 1.3)	1.76 / 5.98 (0.50 / 1.70)	1.41 / 3.87 (0.4 / 1.1)	9.64	3/8	9.67	3/8	B	310	36	LDL/LDK
V2-408060100	2.81 / 6.33 (0.8 / 1.8)	3.17 / 7.74 (0.90 / 2.20)	2.46 / 4.92 (0.7 / 1.4)	12.84	1/2	9.67	3/8	A	285	36	LDL/LDK
V2-408060200	2.81 / 6.33 (0.8 / 1.8)	3.17 / 7.74 (0.90 / 2.20)	2.46 / 4.92 (0.7 / 1.4)	12.84	1/2	9.67	3/8	B	310	36	LDL/LDK
V2-410060300	3.87 / 7.03 (1.1 / 2.0)	4.57 / 8.79 (1.30 / 2.50)	3.17 / 5.63 (0.9 / 1.6)	16.03	5/8	9.67	3/8	C	315	36	LDL/LDK
V2-410060400	3.87 / 7.03 (1.1 / 2.0)	4.57 / 8.79 (1.30 / 2.50)	3.17 / 5.63 (0.9 / 1.6)	16.03	5/8	9.67	3/8	D	335	36	LDL/LDK
V3-410080700	3.87 / 9.50 (1.1 / 2.7)	4.57 / 11.96 (1.30 / 3.40)	3.17 / 7.39 (0.9 / 2.1)	16.03	5/8	12.84	1/2	E	310	36	LDL/LDK
V3-4100H0700	3.87 / 9.50 (1.1 / 2.7)	4.57 / 11.96 (1.30 / 3.40)	3.17 / 7.39 (0.9 / 2.1)	16.03	5/8	12.70 O.D.	1/2 O.D.	E	310	36	LDL/LDK
V3-412080800	3.87 / 9.85 (1.1 / 2.8)	4.57 / 12.31 (1.30 / 3.50)	3.17 / 7.74 (0.9 / 2.2)	19.18	3/4	12.84	1/2	E	350	36	LDL/LDK
V6-414120100	3.87 / 18.99 (1.1 / 5.4)	4.57 / 23.92 (1.30 / 6.80)	3.17 / 14.77 (0.9 / 4.2)	22.36	7/8	19.18	3/4	A	810	18	LDL/LDK
V6-414100100	3.87 / 18.99 (1.1 / 5.4)	4.57 / 23.92 (1.30 / 6.80)	3.17 / 14.77 (0.9 / 4.2)	22.36	7/8	16.03	5/8	A	810	18	LDL/LDK
V6-414080100	3.87 / 18.99 (1.1 / 5.4)	4.57 / 23.92 (1.30 / 6.80)	3.17 / 14.77 (0.9 / 4.2)	22.36	7/8	12.83	1/2	A	810	18	LDL/LDK
V6-412080100	3.87 / 18.99 (1.1 / 5.4)	4.57 / 23.92 (1.30 / 6.80)	3.17 / 14.77 (0.9 / 4.2)	19.18	3/4	12.83	1/2	A	745	18	LDL/LDK
V10-414080100	11.25 / 33.06 (3.2 / 9.4)	13.01 / 41.85 (3.70 / 11.90)	9.85 / 26.03 (2.8 / 7.4)	22.35	7/8	12.83	1/2	A	1'200	12	LDL/LDK
V10-414120100	11.25 / 33.06 (3.2 / 9.4)	13.01 / 41.85 (3.70 / 11.90)	9.85 / 26.03 (2.8 / 7.4)	22.35	7/8	19.18	3/4	A	1'200	12	LDL/LDK
V10-414140400	11.25 / 33.06 (3.2 / 9.4)	13.01 / 41.85 (3.70 / 11.90)	9.85 / 26.03 (2.8 / 7.4)	22.35	7/8	22.36	7/8	A	1'220	12	LDL/LDK
V10-418140100	11.25 / 37.63 (3.2 / 10.7)	13.01 / 47.48 (3.70 / 13.50)	9.85 / 29.54 (2.8 / 8.4)	28.78	1 1/8	22.36	7/8	A	1'310	12	LDL/LDK
V10-418120100	11.25 / 37.63 (3.2 / 10.7)	13.01 / 47.48 (3.70 / 13.50)	9.85 / 29.54 (2.8 / 8.4)	28.78	1 1/8	19.18	3/4	A	1'310	12	LDL/LDK
V10-414100100	11.25 / 33.06 (3.2 / 9.4)	13.01 / 41.85 (3.70 / 11.90)	9.85 / 26.03 (2.8 / 7.4)	22.35	7/8	16.03	5/8	A	1'200	12	LDL/LDK
V10-414120200	17.23 / 33.06 (4.9 / 9.4)	19.73 / 41.85 (5.61 / 11.90)	14.42 / 26.03 (4.1 / 7.4)	22.35	7/8	19.18	3/4	A	1'190	12	LDL/LDK
V10-4180M0200	17.23 / 37.63 (4.9 / 10.7)	19.73 / 47.48 (5.61 / 13.50)	14.42 / 29.54 (4.1 / 8.4)	28.78	1 1/8	19.05 O.D.	3/4 O.D.	A	1'300	12	LDL/LDK
V10-418100200	17.23 / 37.63 (4.9 / 10.7)	19.73 / 47.48 (5.61 / 13.50)	14.42 / 29.54 (4.1 / 8.4)	28.78	1 1/8	16.03	5/8	A	1'300	12	LDL/LDK
V10-418120200	17.23 / 37.63 (4.9 / 10.7)	19.73 / 47.48 (5.61 / 13.50)	14.42 / 29.54 (4.1 / 8.4)	28.78	1 1/8	19.18	3/4	A	1'300	12	LDL/LDK
V10-418140200	17.23 / 37.63 (4.9 / 10.7)	19.73 / 47.48 (5.61 / 13.50)	14.42 / 29.54 (4.1 / 8.4)	28.78	1 1/8	22.36	7/8	A	1'300	12	LDL/LDK
V12-4220T0200	22.86 / 46.78 (6.5 / 13.3)	26.38 / 58.91 (7.50 / 16.75)	18.99 / 36.93 (5.4 / 10.5)	35.13	1 3/8	28.58 O.D.	1 1/8 O.D.	F	2'030	6	LDL/LDK

O.D. = Outdoor Diameter  
C.T.S. = Copper Tube Style  
S.E.C. = Suction Evaporator Condenser

PLEASE NOTE: Capacities shown are based on:  
Evaporating temperature: 7,2°C; Sub Cooling: 5,0°C; Condensing Temperature: 54,4°C; Superheat: 5,0°C; Pressure Drop: 0,014 MPa

### AVAILABLE PIPE CONFIGURATIONS



# Reversing Valves Table



## N-Series



Part Number	R407C kW min/max (US ton min/ max)	R410A kW min/max (US ton min/max)	R134A kW min/max (US ton min/max)	C.T.S.				Style	Mass (g) (W/O coil)	Qty/ box	Coil
				S.E.C.		Discharge					
				mm	Inch	mm	Inch				
N15C00S *	15.83 / 54.51 (4.50 / 15.50)	15.83 / 61.55 (4.50 / 17.50)	12.31 / 40.80 (3.50 / 11.60)	28.80	1 1/8	22.40	7/8	A	1'260		LDL/LDK
N20C00G *	17.59 / 72.45 (5.00 / 20.60)	17.60 / 81.60 (5.00 / 23.20)	13.72 / 54.16 (3.90 / 15.40)	32.00	1 1/4	25.60	1	A	3'100	1	LDL/LDK
N20C10G	17.59 / 72.45 (5.00 / 20.60)	17.60 / 81.60 (5.00 / 23.20)	13.72 / 54.16 (3.90 / 15.40)	32.00	1 1/4	25.60	1	A	3'200	1	LDL/LDK
N20C01G *	17.59 / 72.45 (5.00 / 20.60)	17.60 / 81.60 (5.00 / 23.20)	13.72 / 54.16 (3.90 / 15.40)	34.90	1 3/8	28.60	1 1/8	A	3'100	1	LDL/LDK
N20C11G	17.59 / 72.45 (5.00 / 20.60)	17.60 / 81.60 (5.00 / 23.20)	13.72 / 54.16 (3.90 / 15.40)	34.90	1 3/8	28.60	1 1/8	A	3'200	1	LDL/LDK
N30C00G *	26.38 / 108.68 (7.50 / 30.90)	26.40 / 122.40 (7.51 / 34.80)	20.40 / 81.24 (5.80 / 23.10)	38.30	1 1/2	32.00	1 1/4	A	3'200	1	LDL/LDK
N30C10G	26.38 / 108.68 (7.50 / 30.90)	26.40 / 122.40 (7.51 / 34.80)	20.40 / 81.24 (5.80 / 23.10)	38.30	1 1/2	32.00	1 1/4	A	3'300	1	LDL/LDK
N40C10G	35.17 / 144.90 (10.00 / 41.20)	35.20 / 163.20 (10.01 / 46.40)	27.08 / 108.32 (7.70 / 30.80)	45.00	1 7/9	38.10	1 1/2	A	7'500	1	LDL/LDK
N50C10G	35.17 / 181.13 (10.00 / 51.50)	35.20 / 204.00 (10.01 / 58.00)	27.08 / 135.40 (7.70 / 38.50)	54.20	2 1/7	38.10	1 1/2	A	7'600	1	LDL/LDK
N60C10G	52.80 / 194.80 (15.10 / 55.60)	52.80 / 245.00 (15.10 / 70.00)	34.80 / 154.35 (10.00 / 44.10)	67.00	2 5/8	41.50	1 5/8	A	8'900	1	LDL/LDK

\*without mounting brackets

C.T.S. = Copper Tube Style

S.E.C. = Suction Evaporator Condenser

PLEASE NOTE: Capacities shown are based on:  
Evaporating temperature: 7,2°C; Sub Cooling: 5,0°C; Condensing Temperature: 54,4°C; Superheat: 5,0°C; Pressure Drop: 0,014 MPa

### V-N Reversing Valve Operating Specification

Min. Δ Pressure to Reverse	0,15 MPa	Max. Operating Temper.	121°C Min.
Max. Δ Pressure to Reverse	3,04 MPa	Min. Operating Voltage	85% of Rated Volts
Max. working Pressure	4,68 MPa (V Series)	Max. Operating Voltage	110% of Rated Volts
	4,17 MPa (N Series)		
Min. Bursting Pressure	17,23 MPa (V Series)		
	16,7 MPa (N Series)		

# Reversing Valves and Solenoid Coils Table



## VH-Series



Part Number	R407C kW min/max (US ton min/max)	R134A kW min/max (US ton min/max)	R404A kW min/max (US ton min/max)	C.T.S.				Mass (g) (W/O coil)	Qty/box	Coil
				S.E.C.		Discharge				
				mm	Inch	mm	Inch			
VH32085	70.34 / 289.80 (20.00 / 82.40)	54.16 / 216.65 (15.40 / 61.60)	54.16 / 216.65 (15.40 / 61.60)	Flange RBK 65A	Flange RBK 65A	Flange RBK 50A	Flange RBK 50A	55'000	1	LDL/LDK
VH32123	105.51 / 436.11 (30.00 / 124.00)	81.24 / 324.97 (23.10 / 92.40)	81.24 / 324.97 (23.10 / 92.40)	Flange RBK 65A	Flange RBK 65A	Flange RBK 50A	Flange RBK 50A	73'000	1	LDL/LDK
VH32163	140.68 / 579.60 (40.00 / 164.80)	108.32 / 432.59 (30.80 / 123.00)	108.32 / 432.29 (30.80 / 123.20)	Flange RBK 65A	Flange RBK 65A	Flange RBK 50A	Flange RBK 50A	82'000	1	LDL/LDK

C.T.S. = Copper Tube Style  
S.E.C. = Suction Evaporator Condenser

PLEASE NOTE: Capacities shown are based on:  
Evaporating temperature: 7,2°C; Sub Cooling: 5,0°C; Condensing Temperature: 54,4°C; Superheat: 5,0°C; Pressure Drop: 0,014 MPa

## Choosing the correct Solenoid Coil

RANCO offers Type LDK and LDL solenoid coils for use with the entire range of RANCO Heat Pump Reversing Valves. These color coded epoxy encapsulated, continuous duty, moisture resistant magnetic coils are designed to operate the pilot valve controlling the Reversing Valves listed above.

### LDK

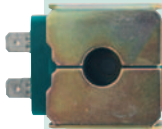

Coil Type	Color	Voltage	Frequency	Wattage 50/60Hz	UL Thermal Class	Cable length	
						mm	inch
LDK-11	Red	12V~	50/60Hz	5/4	A	1200	48
LDK-31	Black	120V~	50/60Hz	5/4	A	1200	48
LDK-41	Green	208 / 240V~	50/60Hz	5/4	A	1200	48
LDK-73	Yellow	12V~	-	10	F	1200	48
LDK-83	Orange	24V~	-	10	F	1200	48

Other cable length available on request. Included with the LDK solenoid coil is a W29 wiring harness with 120 mm leads.

### LDL



Coil Type	Color	Voltage	Frequency	Wattage 50/60Hz	UL Thermal Class	Cable length	
						mm	inch
LDL-11	Red	12V~	50/60Hz	5/4	A	1200	48
LDL-41	Green	208 / 240V~	50/60Hz	5/4	A	1200	48
LDL-41	Green	208 / 240V~	50/60Hz	5/4	A	2000	80

Other cable length available on request.

### VH Reversing Valve Operating Specification

Min. Δ Pressure to Reverse	0,34 MPa	Max. Operating Temper.	120°C Min.
Max. Δ Pressure to Reverse	2,25 MPa	Min. Operating Voltage	85% of Rated Volts
Max. working Pressure	3,3 MPa	Max. Operating Voltage	110% of Rated Volts
Min. Bursting Pressure	16,5 MPa		

# Description Application

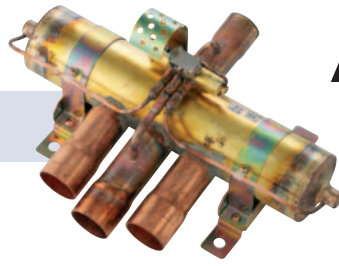

These solenoid operated Reversing Valves are slide type, 4-way with a 4-way Pilot valve and operate under the full pressure of the heat pump system. The valves are used on unitary, split system, and window-type heat pump applications. There are six different styles designed to meet your particular system need.

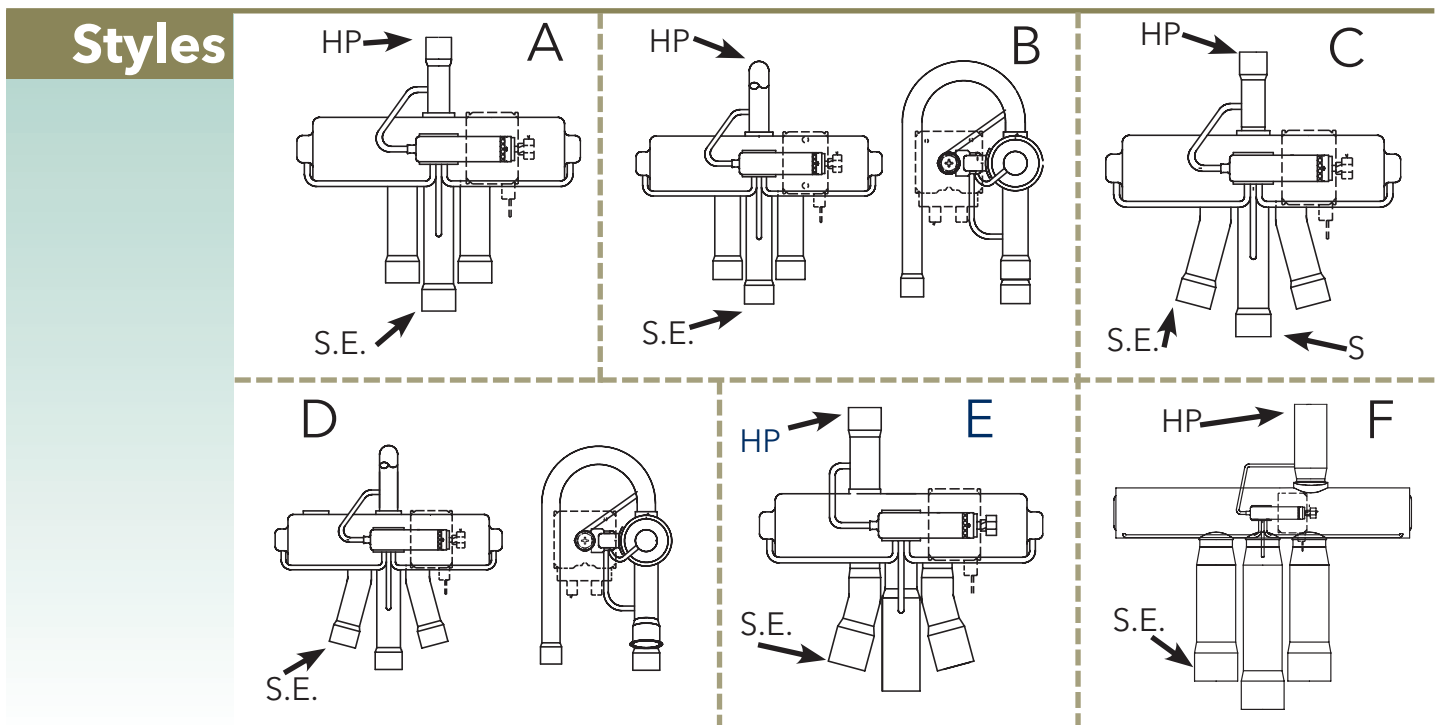

## Legenda

HP	High Pressure
S	Suction
S.E.	Connected to High Pressure when Solenoid is Energized

## Disclaimer

This document and its contents remain the sole property of Eliwell Controls S.r.l., and shall not be reproduced or distributed without authorization. Although great care has been exercised in the preparation of this document, Eliwell Controls S.r.l., its employees or its vendors, cannot accept any liability whatsoever connected with its use. Eliwell Controls S.r.l. reserves the right to make any changes or improvements without prior notice.